



# INSTALLATION INSTRUCTIONS

## Product

7160-0750, 7160-0775, 7160-0776  
Riveted Clevis w/ Anchor Plate Assembly  
Riveted Short Clevis w/ Anchor Plate Assembly  
Riveted Tall Clevis w/ Anchor Plate Assembly

## Revision

Rev B

## Form

INST-676

Printing Spec: PS-001

Tighten or loosen nut  
for desired swivel tension

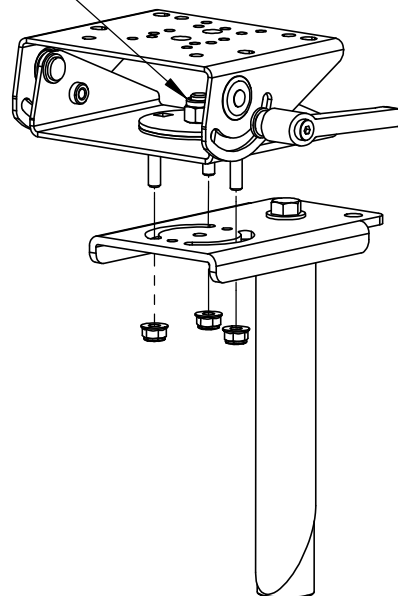

## INSTALL ON EQUIPMENT WITH GAMBER-JOHNSON SWIVEL PATTERN CUTOUT

1. Remove 1/4-20 flange lock nuts from clevis.
2. Place Clevis on equipment with studs going through the curved slots on mounting surface.
3. Re-attach flange nuts and tighten in place.

### Product Mounting Disclaimer

Gamber-Johnson is not liable under any theory of contract or tort law for any loss, damage, personal injury, special, incidental or consequential damages for personal injury or other damage of any nature arising directly or indirectly as a result of the improper installation or use of its products in vehicle or any other application. In order to safely install and use Gamber-Johnson products full consideration of vehicle occupants, vehicle systems (i.e., the location of fuel lines, brakes lines, electrical, drive train or other systems), air-bags and other safety equipment is required. Gamber-Johnson specifically disclaims any responsibility for the improper use or installation of its products not consistent with the original vehicle manufactures specifications and recommendations, Gamber-Johnson product instruction sheets, or workmanship standards as endorsed through the Gamber-Johnson Certified Installer Program.

© Copyright 2015 Gamber-Johnson, LLC

If you need assistance or have questions, call Gamber-Johnson at 1-800-456-6868