



with Clear Duty® Technology

FASCIA LIGHTS - 4" ECE R65 Class 2 Certified

- EMPS2QME3(x) - QUICK MOUNT
- EMPS2SME3(xxx)- SCREW MOUNT
- EMPS2STE3(xxx) - STUD MOUNT THREADED

FASCIA LIGHTS - 3" ECE R65 Class 2 Certified

- EMPS1QME3(x) - QUICK MOUNT
- EMPS1SME3(xxx)- SCREW MOUNT
- EMPS1STE3(xxx) - STUD MOUNT THREADED

TECHNICAL SPECIFICATIONS					
Dimensions (From Mounting Surface)					
4" Screw Mount:	4.52"L x 0.92"H x 0.42"D				
4" Stud, Threaded Mount:	4.04"L x 0.92"H x 0.42"D				
4" Quick Mount:	4.04"L x 0.92"H x 0.42"D				
3" Screw Mount:	3.425"L x .092"H x 0.42"D				
3" Stud, Threaded Mount:	2.9"L x 0.92"H x 0.42"D				
3" Quick Mount:	2.9"L x 0.92"H x 0.47"D				
Input Voltage:		9-32Vdc			
3 & 4" CURRENT CONSUMPTION (Amps) (Primary)					
		12.8Vdc		25.6Vdc	
		Peak	Average	Peak	Average
Red, Amber, Blue		1.25	0.63	0.63	0.32

WIRE HOOK-UP TABLE	
WIRE COLOR:	FUNCTION:
RED	Power (Primary) By Day
BLACK	Ground
GREEN**	Sync2 *
WHITE to GROUND	Setup Wire (See pg. 8*)
WHITE to POWER	By Night Function Wire
RED/WHITE	Power (Secondary) By Night

** To sync multiple mPower lights, connect the Green wire from each light together.
 * Will NOT work w/ other sync products such as Ghost, LED3, & 4 wire Intersector w/external flasher.
 *Will Work with Sync 2 products nFORCE Secondary Lights, nFORCE FIT and 5 wire Intersector Lights.

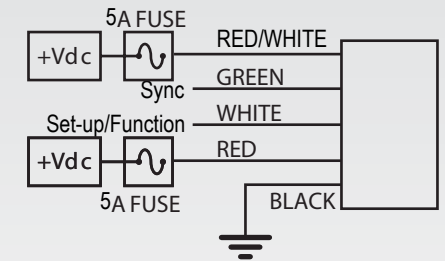

By Day Function:
 Standard Intensity for day time use.

By Night Function:
 Reduced Intensity for night time use.

⚠ WARNING
 This product contains high intensity LED devices. To prevent eye damage, DO NOT stare into the light beam at close range.

Protected by U.S. Patent 10,703,260 and Patents Pending
<https://soundoffsignal.com/legal/patent-notification/>

- ⚠ WARNING**
- HIGH CURRENT interconnects must be properly terminated. Poor crimp quality can cause heat build-up and fire. Follow crimp connector manufacturer instructions.
 - DO NOT install this product or route any wires in the Air Bag Deployment Zone. Refer to vehicle Owner's Manual for deployment zones.
 - Unit may become hot to touch during normal operation.
 - Failure to properly install connectors, fuses or wiring may cause vehicle failure or fire.
 - Installation must only be performed by trained technician. Installer must determine vehicle wiring configuration and proper integration of system.
 - Use proper wire gauge. All power wires connecting to positive (+) or negative (-) battery terminal or local chassis ground (-) must be sized to supply at least 125% of max. current and properly fused at power source.
 - Install protective grommets when routing wire through firewall or metal.

NOTICE:

Installers and users must comply with all applicable federal, state and local laws regarding use and installation of warning devices.
 Improper use or installation may void warranty coverage. To review our Limited Warranty Statement & Return Policy for this or any SoundOff Signal product, visit our website at www.soundoffsignal.com/sales-support. If you have questions regarding this product, contact **Technical Services**, Monday - Friday, 8 a.m. to 5 p.m. at 1.800.338.7337 (press #4 to skip the automated message). Questions or comments that do not require immediate attention may be emailed to techservices@soundoffsignal.com.



with Clear Duty® Technology

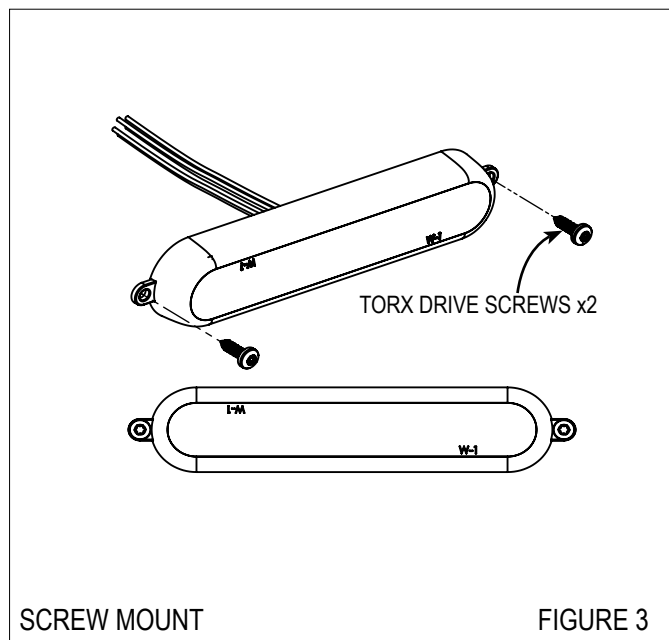
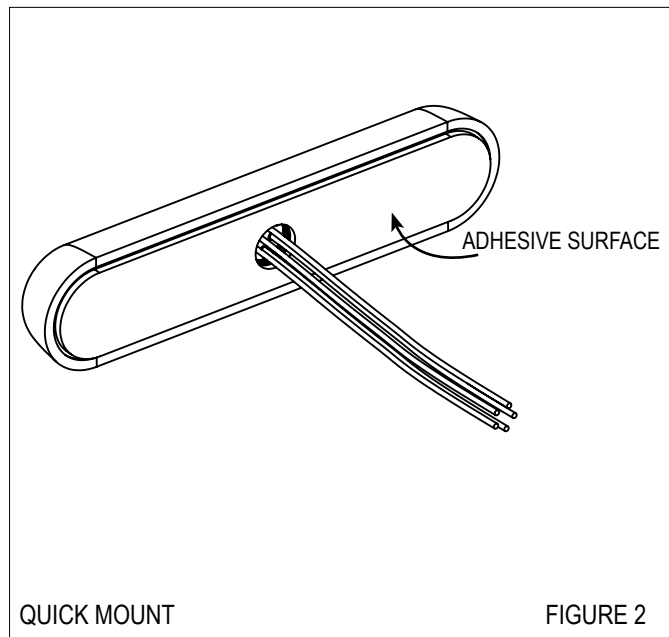
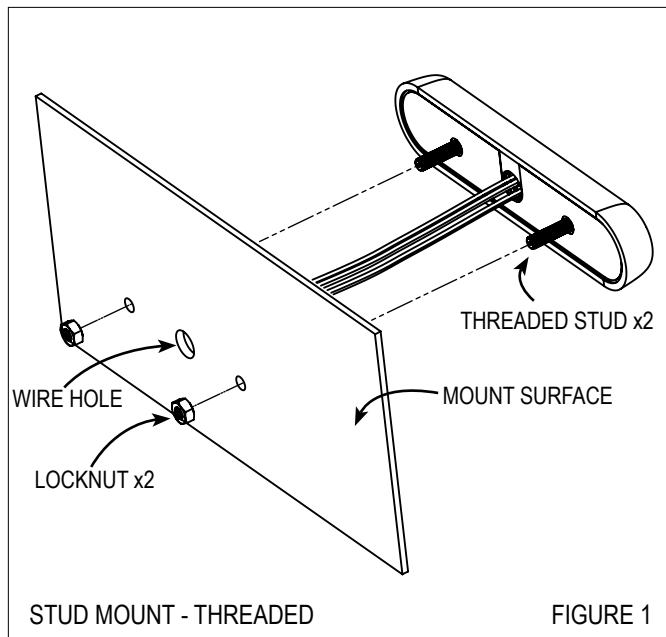

INSTALLATION:

Stud Mount, Threaded (Figure 1)

1. Pre-Drill per stud mount pattern indicated on page 11 (3") or per the supplied mounting template (4").
2. Clean the surface as required.
3. Deburr hole as required.
4. Make wire connections and feed wire through the drilled wire hole.
5. Install light, inserting 2 studs into the 2 drilled holes.
6. Install 2 lock nuts onto studs behind mount surface.
Hand tighten only until mount surface and light are flush.

Quick Mount (Figure 2)

1. Pre-Drill per quick mount pattern indicated on page 10 (4") or page 11 (3"). (Wire hole only).
2. Deburr hole as required.
3. Clean surface with supplied alcohol wipe.
4. Make wire connection and feed wire through the drilled wire hole.
5. Remove adhesive backer and align light into desired position. Apply to surface and hold firmly for 30 seconds. **CAUTION! APPLY UNIFORM PRESSURE ACROSS FULL FACE OF LIGHT.**

Screw Mount (Figure 3)

1. Pre-Drill per screw mount pattern indicated on page 10 (4") or page 11 (3").
2. Deburr and clean the surface as required.
3. Make wire connections and feed the wire through the drilled wire hole.
4. Install light with 2x Torx drive screws and hand tighten only until mount surface and light are flush.

with Clear Duty® Technology

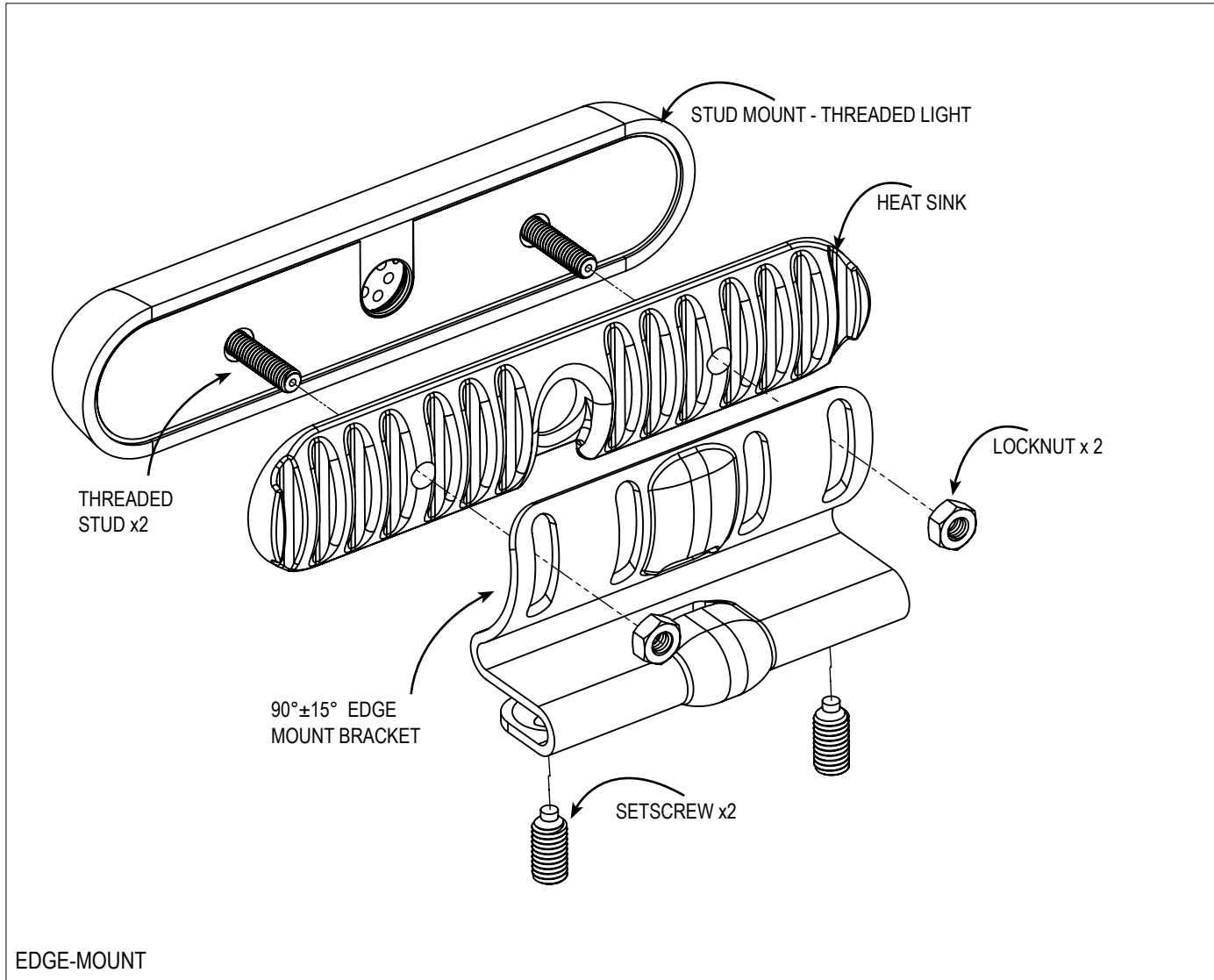

INSTALLATION:

Edge-Mount Bracket

1. Install Heat Sink onto "mPOWER Stud Mount, Threaded" light as indicated. Wire passed through center hole.
2. Install bracket onto "mPOWER Stud Mount, Thread" light as indicated. Wire passed through rear relief and into lower edge grip relief.
3. Install 2 lock nuts onto "mPOWER Stud Mount, Thread" light. Hand tighten until final adjustment.
4. Place bracket over desired vehicle's edge surface (i.e. rear hood), ensure wire is fully seated in rear relief, wrapping around edge lying flat.
5. Tighten 2 setscrews to vehicle's edge surface.
6. Adjust angle of light to desired direction and tighten 2 lock nuts until secure.
7. Make wire connections.

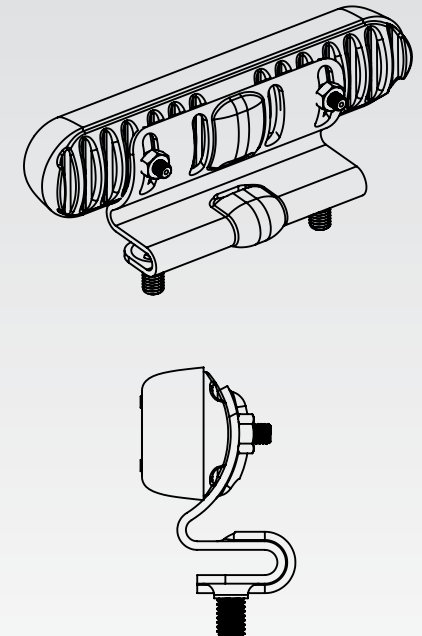

with Clear Duty® Technology

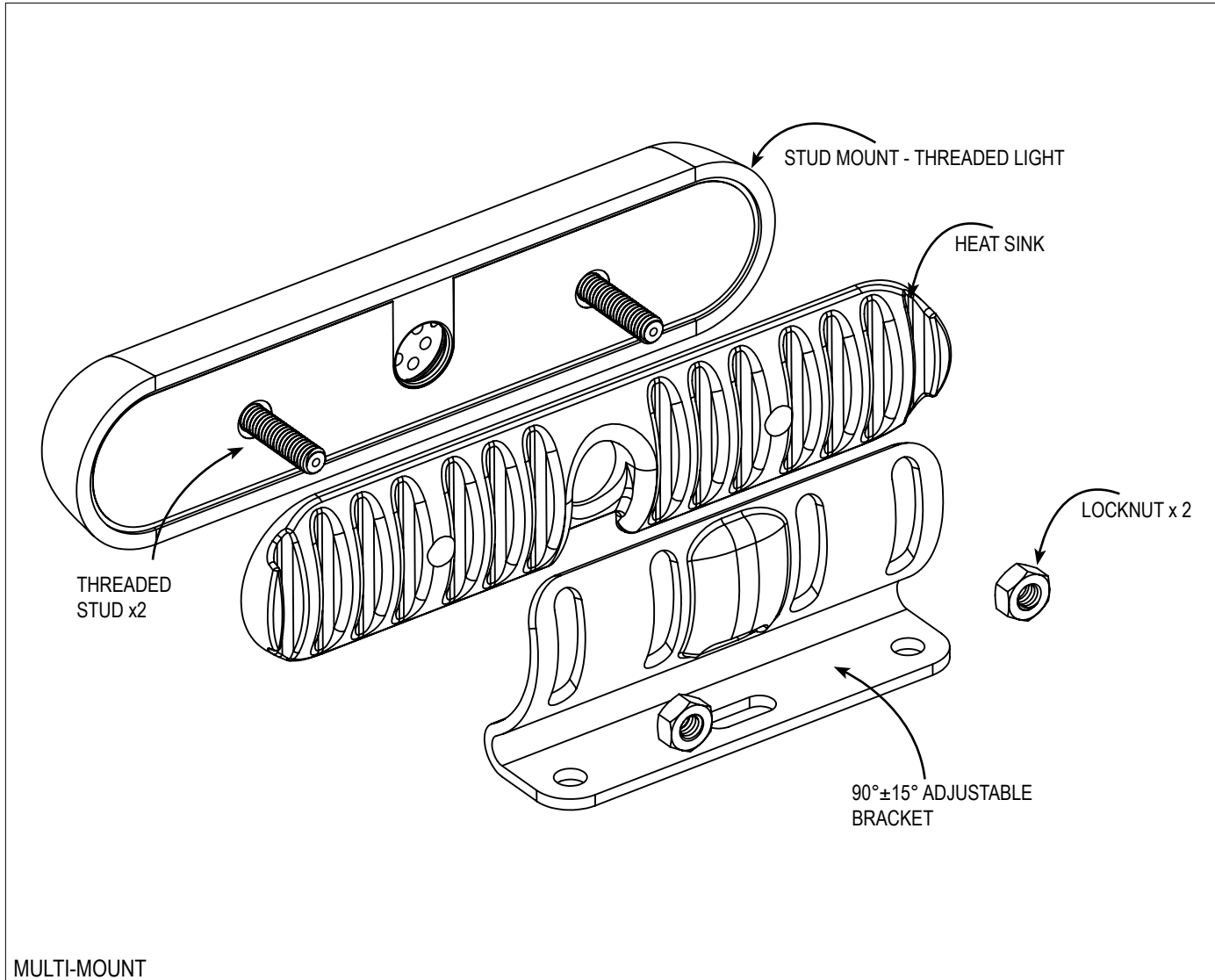

INSTALLATION:

Multi-Mount Bracket

1. Pre-drill mount holes as required (bracket holes and spacing are indicated on page 10 (4") or page 11 (3")).
2. Place bracket onto desired vehicle's surface and secure with screws (not provided).
3. Install Heat Sink onto "mPOWER Stud Mount, Threaded" light as indicated. Wire passes through center hole.
4. Install "mPOWER Stud Mount, Thread" light onto bracket as indicated. Wire passes through rear relief.
5. Install 2 lock nuts onto "mPOWER Stud Mount, Thread" light as indicated. Hand tighten until final adjustment.
6. Adjust angle of light to desired direction and tighten 2 lock nuts until secure.
7. Make wire connections.

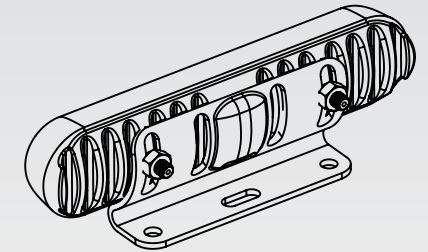

with Clear Duty® Technology

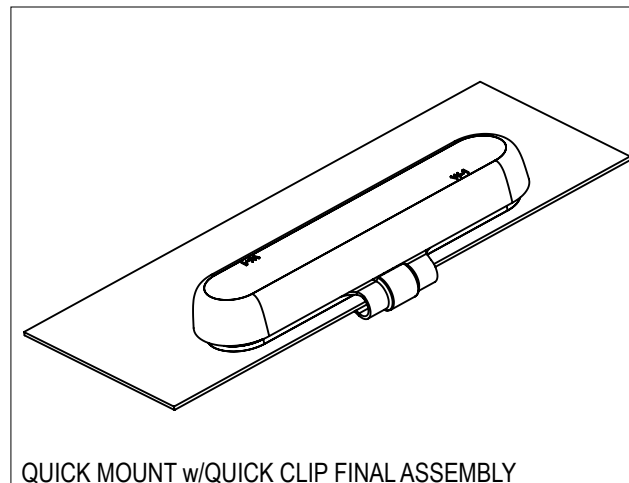
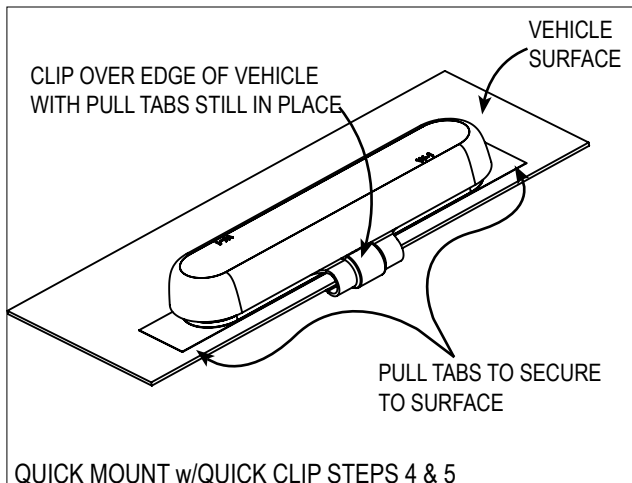
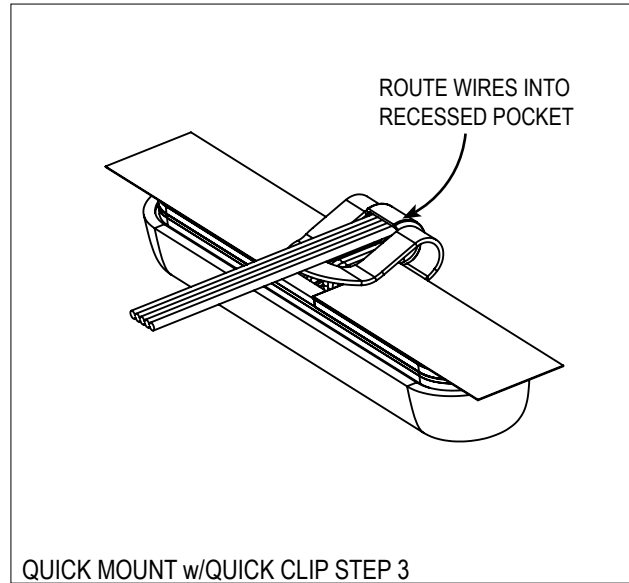
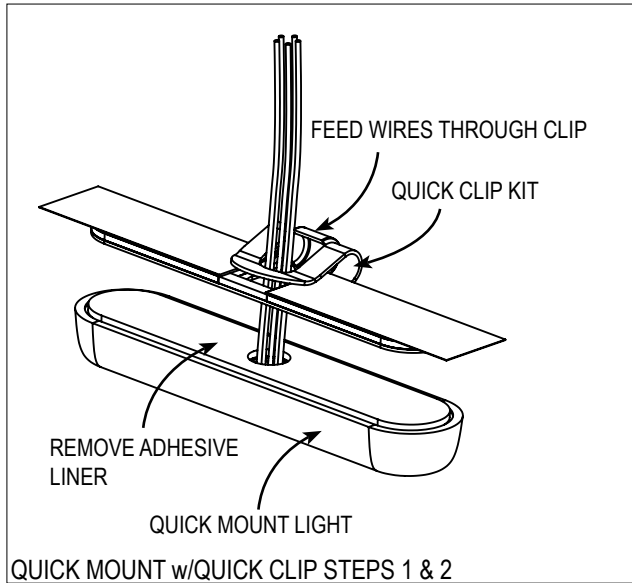

INSTALLATION:

Quick Mount w/Quick Clip

1. Prep surface with supplied alcohol wipe.
2. Feed wires through quick clip as shown.
3. Remove adhesive liner on the light and install clip to light. Make sure to properly align ends before placing down.
4. Route wires into recessed pocket lying flat in pocket.
5. With red pull tabs still in place, clip light over edge of vehicle surface. Be careful to make sure red pull tabs **DO NOT PEEL, FOLD UNDER OR WRINKLE**. Make sure wire is lying flat and is not pinched.
6. With light properly oriented, pull red tabs to secure light to surface.
7. Make wire connections.



with Clear Duty® Technology

OVER-VOLTAGE PROTECTION

When an over-voltage condition is detected, the module will flash an over-voltage warning pattern of 50mS ON/950mS OFF to alert of the over-voltage condition and protect the electronics from damage due to heat/voltage.

THERMAL COMPENSATION PROTECTION

The LED module is designed to provide maximum power output while providing protection to the electronic components by reducing the output power at extreme temperatures.

SYNC 2

Synchronizing the flashing of multiple light modules is accomplished by connecting the Green wires of different light modules together. Up to 24 light modules can be connected for synchronized flashing. All light module flash patterns must be set to the same flash pattern # to ensure proper operation. Refer to the Sequence Type section in Set-Up Table (page 8) to setup light modules to flash in alternate or simultaneous flash pattern. NOTE: Will NOT work with non-Sync 2 products such as Ghost and LED3. WILL WORK with Sync 2 products nFORCE Secondary Lights, nFORCE FIT, mPower and 5 wire Intersector Lights.

FLASH PATTERNS	
PATTERN #	SINGLE COLOR
1	ECE Single
2	ECE Dual
3	ECE Triple

FUNCTION TABLES

Changing the function table is only enabled when the LED module is in primary flashing mode. The functional operation of the LED module can be changed while applying +V to the Red wire with the black wire connected to ground. When the light is flashing, momentarily connect the White wire to ground for >4S and <5S (light will go steady high, steady low, off, steady high, steady low) then release. The function table will now advance to the next table (table 1 to table 2, table 2 to table 3, or table 3 to table 1). Repeat above process until required function table is active.

FUNCTION TABLE 1			
WIRE			LIGHT
RED	R/W	WHT	SINGLE
+9-32V			FLASH "BY DAY"
	+9-32V		FLASH "BY NIGHT"
+9-32V	+9-32V		FLASH "BY NIGHT"
		+9-32V	NO OP
+9-32V		+9-32V	FLASH "BY NIGHT"
	+9-32V	+9-32V	FLASH "BY NIGHT"
+9-32V	+9-32V	+9-32V	FLASH "BY NIGHT"

FUNCTION TABLE 2			
WIRE			LIGHT
RED	R/W	WHT	SINGLE
+9-32V			FLASH "BY DAY"
+9-32V		+9-32V	FLASH "BY NIGHT"
	+9-32V		CRUISE
	+9-32V	+9-32V	CRUISE
+9-32V	+9-32V	+9-32V	FLASH "BY NIGHT"
		+9-32V	NO OP
+9-32V	+9-32V		FLASH "BY DAY"

FUNCTION TABLE 3			
WIRE			LIGHT
RED	R/W	WHT	SINGLE
+9-32V			FLASH "BY DAY"
	+9-32V		STEADY CLR 1
+9-32V	+9-32V		STEADY CLR 1
		+9-32V	NO OP
+9-32V		+9-32V	CRUISE
	+9-32V	+9-32V	STEADY CLR 1
+9-32V	+9-32V	+9-32V	STEADY CLR 1





with Clear Duty® Technology

SIMULTANEOUS/ALTERNATE

This function can only be changed when the LED module is in primary flashing mode and only has an effect when at least 2 LED modules have the green sync wire connected together. When the light is flashing, momentarily connect the white wire to ground for >3S and <4S (light will go steady high, steady low, off, steady high) then release. The light module will switch between Simultaneous and Alternate each time this sequence is done. To have light modules flash simultaneously, both light modules need to be set to the same sequence type (Set-Up Table). To have light modules flash alternately, the light modules need to be set to different sequence types (Set-Up Table).

ADVANCE PATTERN

Flash pattern can only be changed when the LED module is in primary flashing mode. When the light is flashing, momentarily connect the white wire to ground for >250mS and <1S (light will go steady high) then release. The flash pattern will advance to the next pattern. If the light module was at the last pattern, the pattern will reset to the 1st pattern.

BACKUP PATTERN

This function is only valid when the LED module is in primary flashing mode. When the light is flashing, momentarily connect the white wire to ground for >1S and < 2S (light will go steady high, steady low) then release. The flash pattern will backup to the previous pattern. If the light module was at the first pattern, the pattern will change to the last pattern on the list.

PATTERN RESET

This function is only valid when the LED module is in primary flashing mode. When the light is flashing, momentarily connect the white wire to ground for >5S and <6S (light will go steady high, steady low, off, steady high, steady low, off) then release. The flash pattern will reset to the 1st pattern in the list.

FACTORY RESET

This function is only valid when the LED module is in primary flashing mode. When the light is flashing, momentarily connect the white wire to ground for >6S and <7S (light will go steady high, steady low, off, steady high, steady low, off, steady high) then release. The LED module will reset to: pattern=1, Function Table=1, Simultaneous.

SETUP TABLE			
SECONDS		USER INTERFACE	
FROM	TO	VISUAL FEEDBACK	ACTION TAKEN
0	1	STEADY-HIGH (60%)	FORWARD ONE PATTERN
1	2	STEADY-LOW (30%)	BACKWARD ONE PATTERN
2	3	OFF	COLOR SWAP (OFF OR ON) (NOT APPLICABLE FOR SINGLE COLOR LIGHT)
3	4	STEADY - HIGH (60%)	SEQUENCE TYPE: SIMULTANEOUS OR ALTERNATE
4	5	STEADY - LOW (30%)	SEE FUNCTION TABLE
5	6	OFF	RESET TO PATTERN 1
6	7	STEADY-HIGH (60%)	FACTORY RESET (PATTERN 1, COLOR SWAP: OFF, SIMULTANEOUS) SEPARATE COLOR CONTROL: OFF
If held longer than 7 seconds, the light will go back to flashing the current pattern and no action will be taken.			





with Clear Duty® Technology

REMOTE MODE: FOR USE WITH bluePRINT SYSTEM ONLY

Connecting the Green with Black wire to ground before applying power to the Red wire will place the LED module into remote mode. The light output color can then be directly controlled by the Red wire.

For Cruise mode or Low Power control of the LED module, the signal to the control wires must be 100 +/- 2Hz using the duty cycle inputs listed below to produce the light output.

Cruise Mode Duty Cycle (@ 100Hz)	
Input	Light Output
40%	OFF
50%	5%
60%	10%

Low Power Flash D.C. (@ 100Hz)	
Input	Light Output
70%	30%
80%	40%
90%	50%



FASCIA LIGHTS - 4"

SCREW MOUNT HOLE TEMPLATE

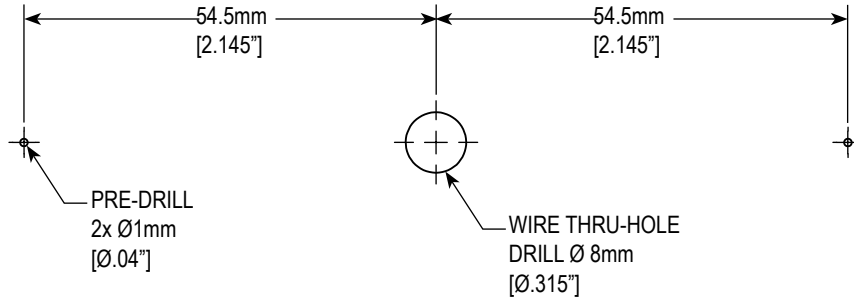

QUICK MOUNT HOLE TEMPLATE

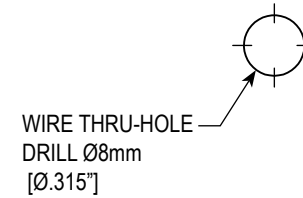

MULTI-MOUNT BRACKET

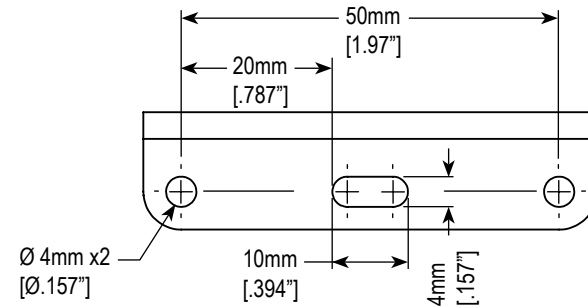

IMPORTANT NOTE:

Due to variations in the printing process and environmental factors, the sizes shown may not be accurate. If this document is used as a cutting template, it is the installers responsibility to confirm the accuracy of the dimensions shown and adjust accordingly.

FASCIA LIGHTS - 3"

3" SCREW MOUNT HOLE TEMPLATE

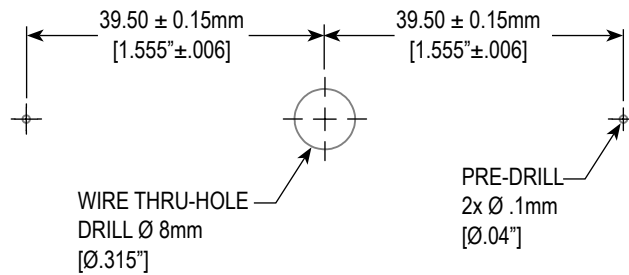

QUICK MOUNT HOLE TEMPLATE

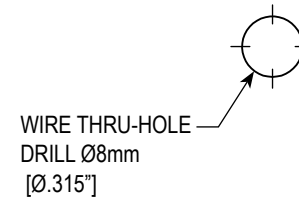

STUD MOUNT HOLE TEMPLATE

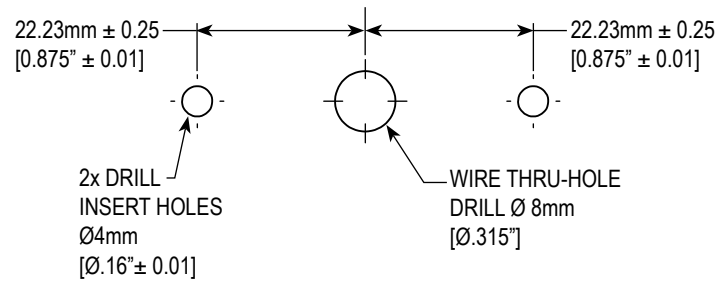

MULTI-MOUNT BRACKET

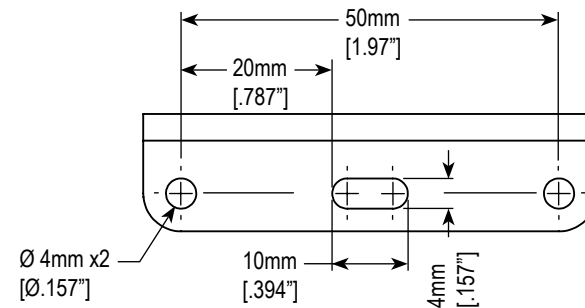

IMPORTANT NOTE:

Due to variations in the printing process and environmental factors, the sizes shown may not be accurate. If this document is used as a cutting template, it is the installers responsibility to confirm the accuracy of the dimensions shown and adjust accordingly.